

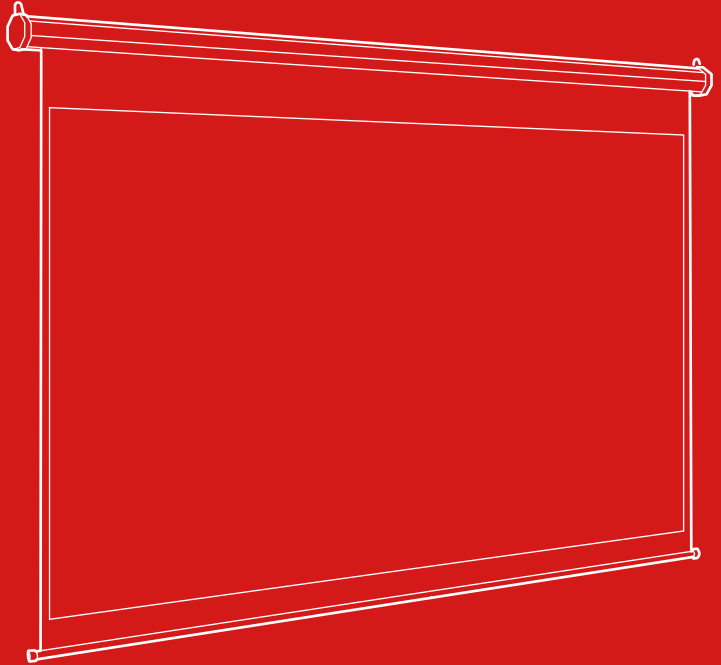

bestchoiceproducts



INSTRUCTION MANUAL

4:3 Electric
Projection Screen

WARNING

Please retain these instructions for future reference.

- This product is intended for use as a projection screen. Do not use this product outside of its intended use.
- Do not mount screen with mounting hardware that has a lower weight capacity than the weight of this product (the weight of this product is approximately 17.4 lbs.).
- Do not hang from any part of this product. Refrain from hanging objects from any part of screen or case.
- This product is not a toy. Do not let children play with the screen.
- Do not attempt to hang screen except from the hooks/screw holes on the sides of the case. If hooks/screw holes break, discontinue hanging until they can be repaired.

SCREEN OPERATION

- This projection screen is operated with either the control switch or the remote control.

Note: The screen cannot be opened and closed manually.

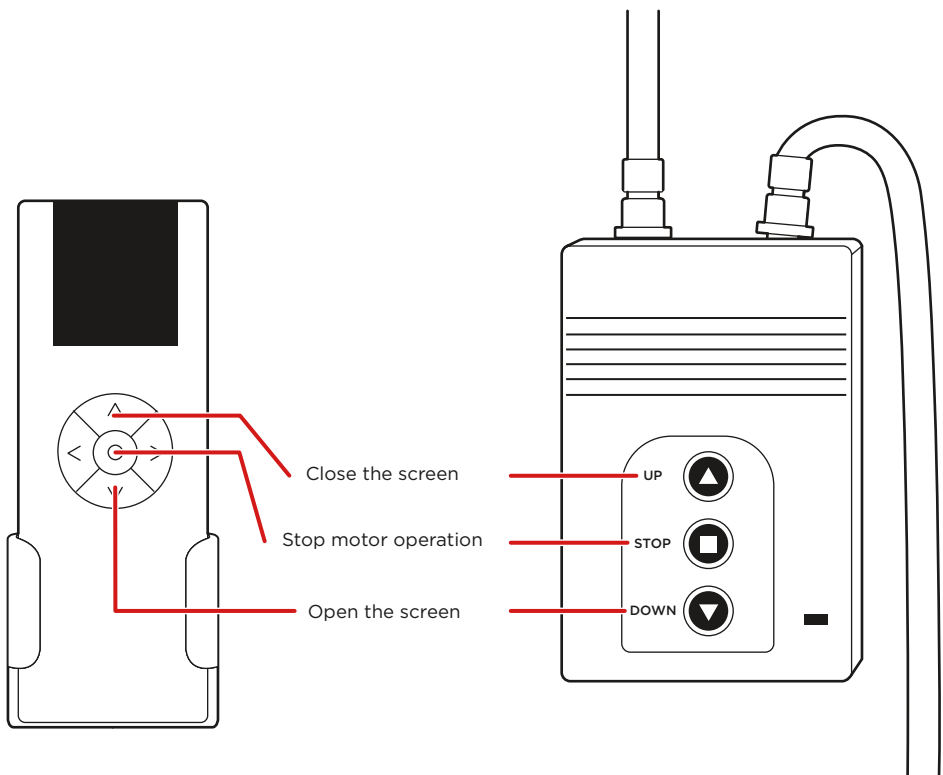

MOUNTING THE SCREEN

- This projection screen can be either mounted on a wall or on the ceiling. Only mount from the hooks on opposite sides of the case.

Note: Mounting hardware is NOT included.

Mounting on the wall

- Insert screws horizontally into the wall at the designated hanging location.
 - You may need to use an electric drill to pre-drill holes into the wall.
- Hang the projector screen from the screw holes on the case.

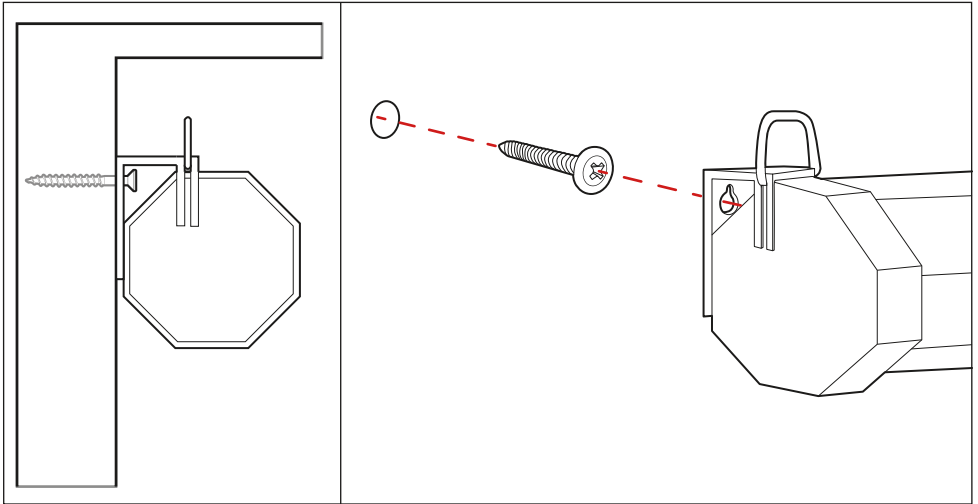

Mounting on the ceiling

- Screw hanging hooks vertically into the ceiling at the designated hanging location.
 - You may need to use an electric drill to pre-drill screw holes into the wall.
- Hang the projector screen from the hooks on the case.

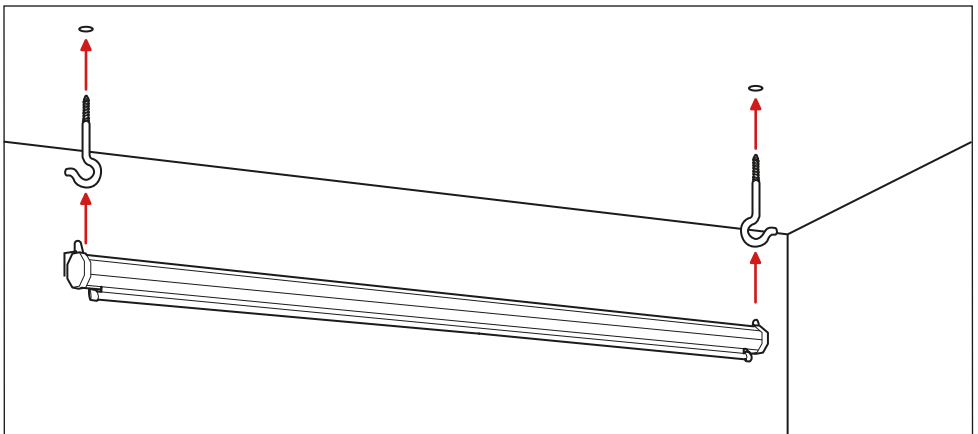

ENJOY YOUR NEW SCREEN!

bcp

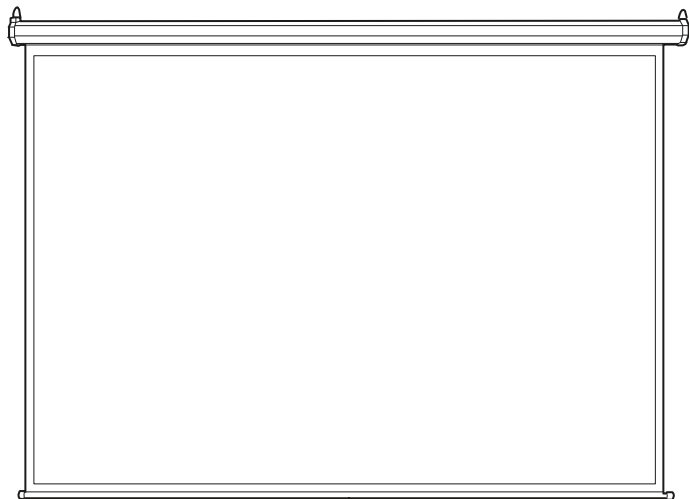

PRODUCT WARRANTY INFORMATION

All items can be returned for any reason within 60 days of the receipt and will receive a full refund as long as the item is returned in its original product packaging and all accessories from its original shipment are included. All returned items will receive a full refund back to the original payment method. All returned items will not be charged a re-stocking fee.

All returned items require an RA (Return Authorization) number, which can only be provided by a Best Choice Products Customer Service Representative when the return request is submitted. Items received without an RA may not be accepted or may increase your return processing time. Once an item has been received by Best Choice Products, refunds or replacements will be processed within 5 business days.

All returns must be shipped back to the Best Choice Products Return Center at the customer's expense. If the reason for return is a result of an error by Best Choice Products then Best Choice Products will provide a pre-paid shipping label via email. Boxes for return shipping will not be provided by Best Choice Products, and is the customer's responsibility to either use the original shipping boxes or purchase new boxes.

Pictures may be required for some returns to ensure an item is not damaged prior to its return. Items returned are not considered undamaged until they are received by Best Choice Products and verified as such. All damages to items are the customer's responsibility until the item has been received by and acknowledge by Best Choice Products as undamaged.

CONTACT US; WE'RE HERE 7 DAYS A WEEK TO HELP YOU!



bestchoiceproducts.com



customerservice@bestchoiceproducts.com



844.948.8400



[LEARN MORE!](#)

! WARNING

Manufacturer and seller expressly disclaim any and all liability for personal injury, property damage or loss, whether direct, indirect, or incidental, resulting from the incorrect attachment, improper use, inadequate maintenance, or neglect of this product.