

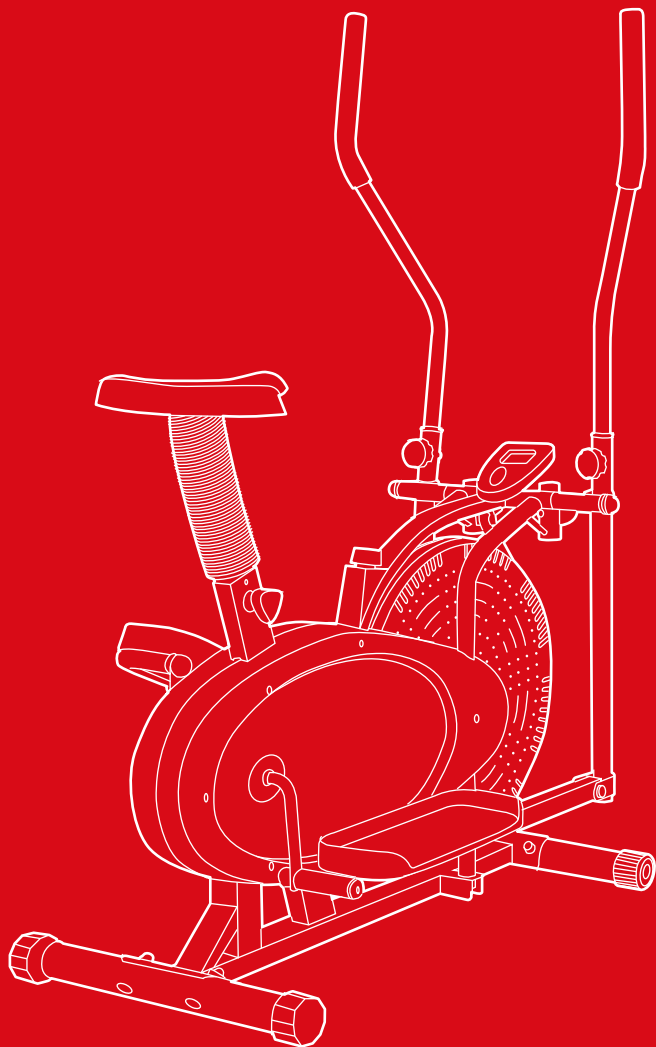

bestchoiceproducts



INSTRUCTION MANUAL

Elliptical Bike

TOOLS REQUIRED

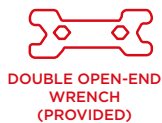

1 PERSON
ASSEMBLY



APPROXIMATELY
45 MIN
ASSEMBLY

HARDWARE

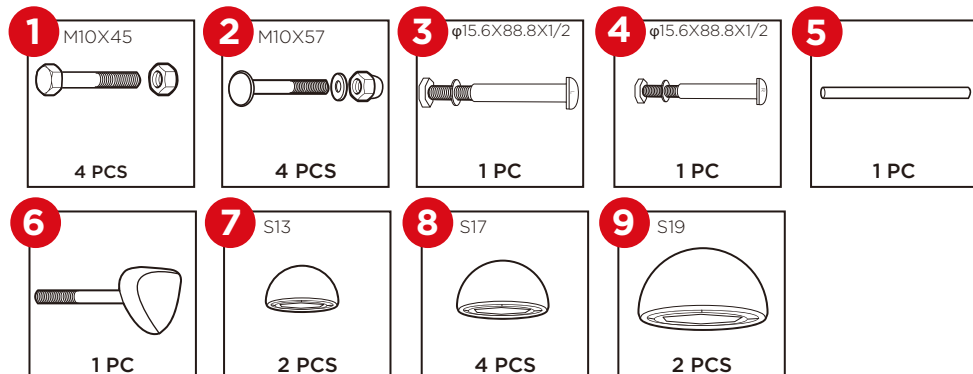

PARTS

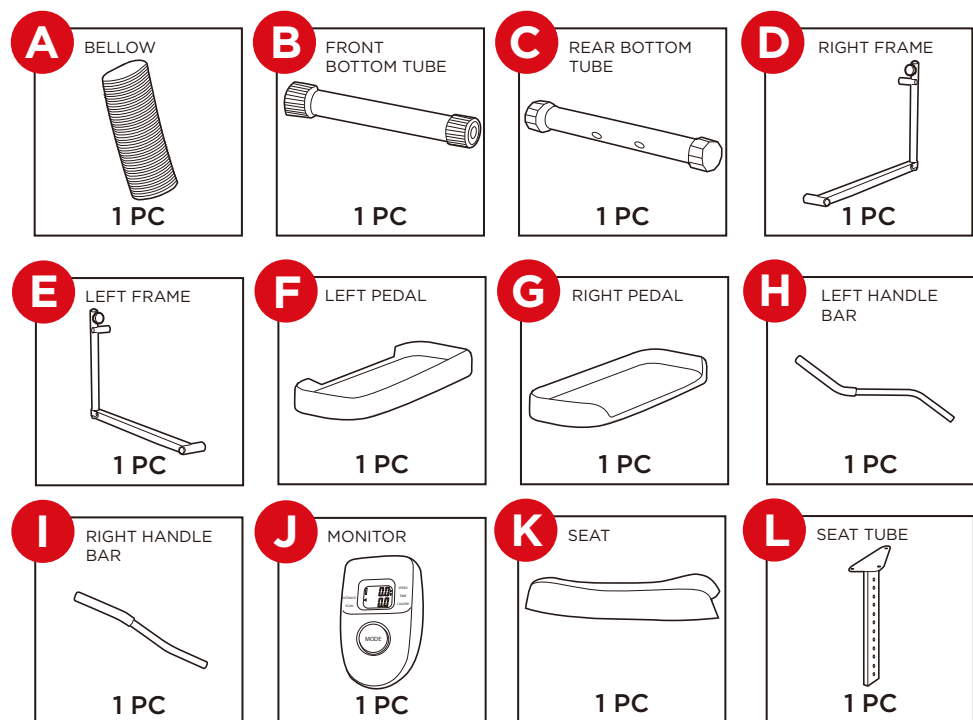

PRODUCT ASSEMBLY

Please retain these instructions for future reference.

1

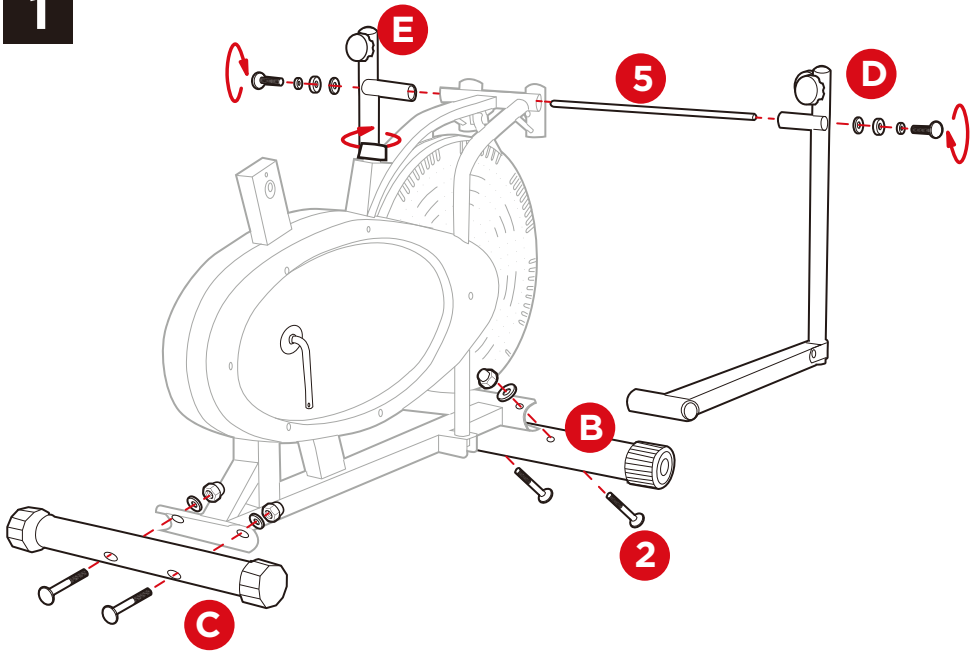

Loosen the tension with the knob on the main frame. Install the part B front bottom tube and part C rear bottom tube with two part 2 nut, bolt, and washer sets on each side.

Note: The front bottom tube has wheels to easily maneuver your elliptical.

Remove the hardware from the part 5 handle bar shaft to insert it through the part D right frame, main frame, and part E left frame. Replace the hardware in the appropriate places as shown.

Note: Use two Allen wrenches to tighten both ends of the handle bar shaft at the same time. Tighten one side clockwise and the other side counterclockwise.

FRONT VIEW

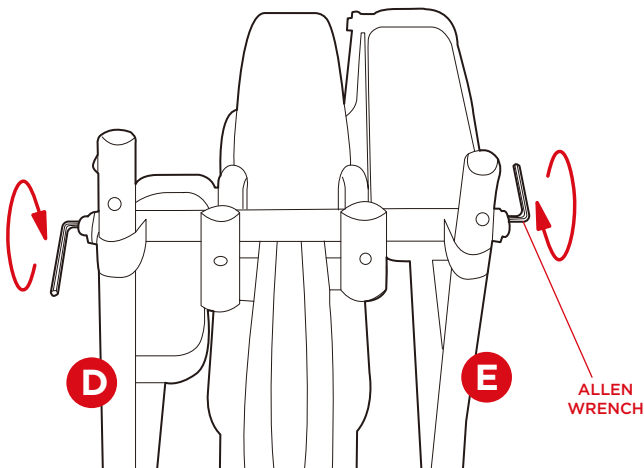

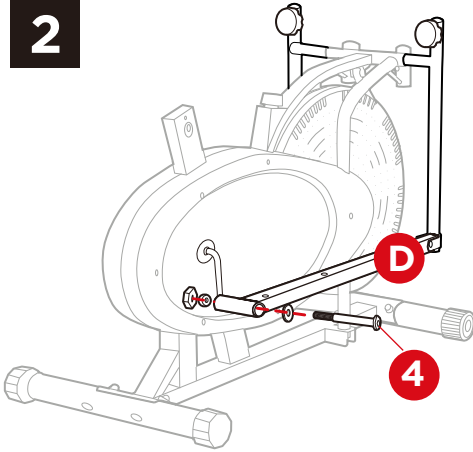
2

Remove hardware from part 4 pedal hinge bolt (right) and insert it through part D right frame, replacing the hardware in the appropriate places as shown. Repeat this process on the left side with part 3 and part E.

NOTE: The left pedal hinge bolt must be screwed counter-clockwise, and the right must be screwed clockwise. If the bolt does not screw easily, rotate the pedal to adjust the height of the bolt.

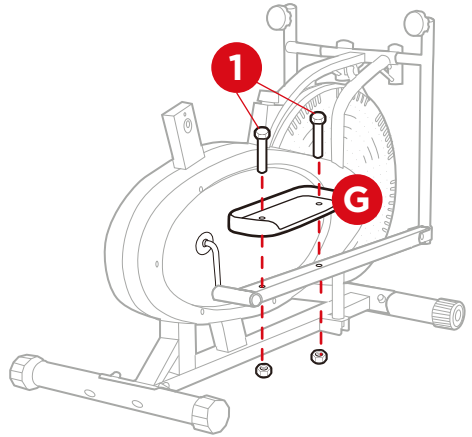
3

Install part F and G pedals with four part 1 nut and bolt sets, two on each pedal.

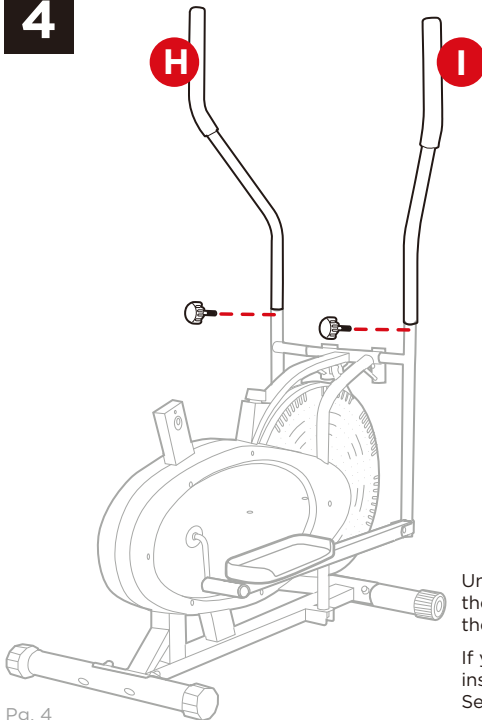
4

INSTALLING FIXED HANDLE BARS

FRONT VIEW

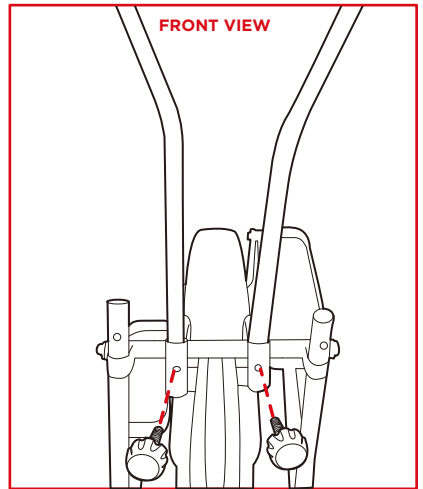

Unscrew the knobs on the left and right frames, install the parts H and I right/left handle bars, then replace the knobs to secure the handle bars.

If you would like the handle bars to be fixed in place, install them in the slots directly above the flywheel. Secure them with the knobs from the right/left frames.

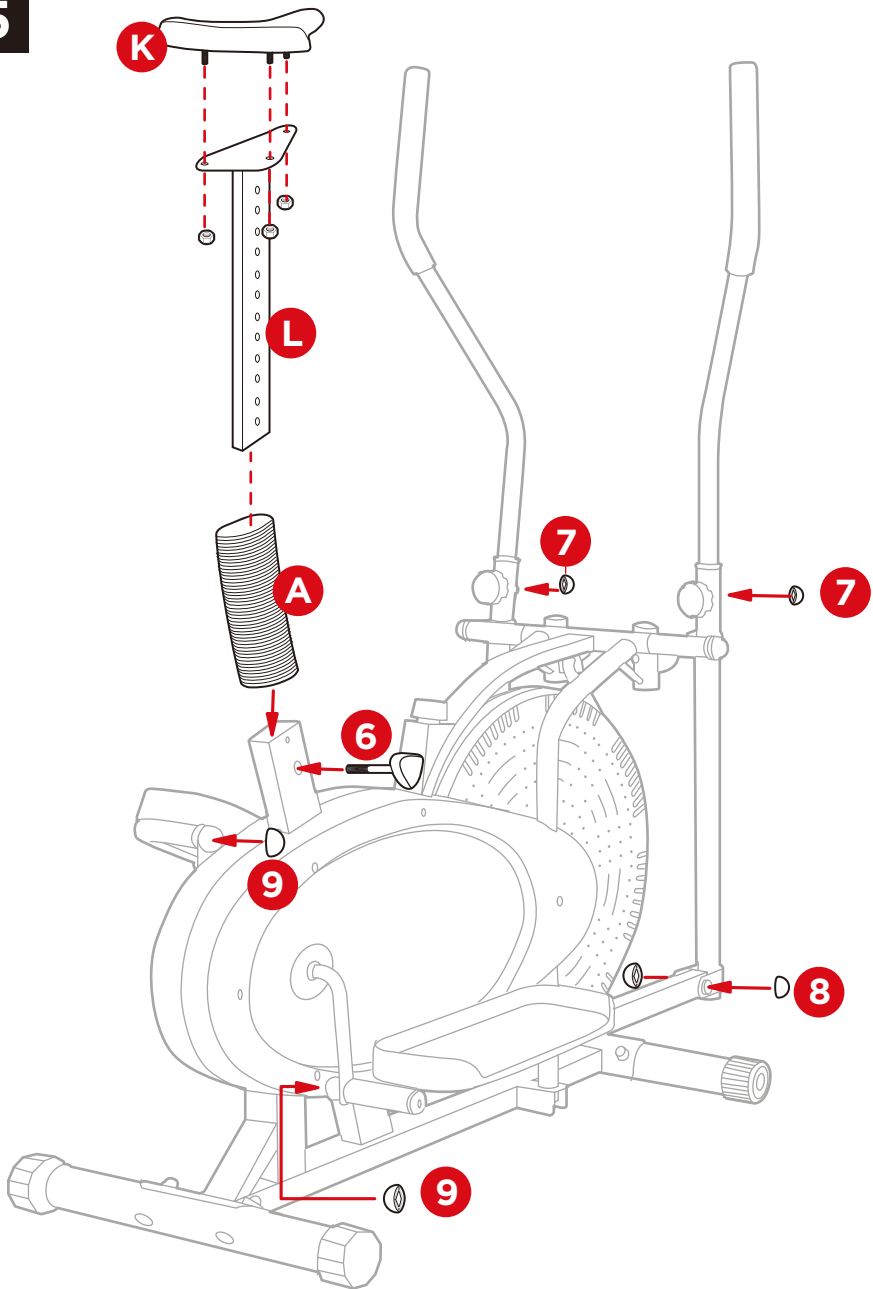
5

Remove hardware from the part K seat and use the same hardware to attach the seat to the part L seat tube. Then, slide the part A bellow onto the seat tube and slide the assembled seat onto the main frame. Use a part 6 tri-knob to secure it in place.

Install part 7, 8, and 9 nut caps in the appropriate locations.

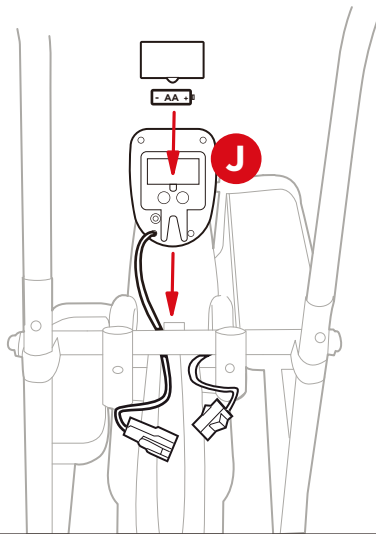

Insert a AA battery into the part J monitor. Slide the monitor onto the bracket between the handle bars. Join the wire from the monitor to the wire on the elliptical.

CAUTION DURING USE

- Please read the manual carefully before beginning to exercise.
- Place the machine on flat ground. Do not use it in the following places:
 - Outdoors
 - Near water
 - Slanted ground
 - Near heat sources like a heater/fireplace
 - Places with excessive noise
 - Enclosed spaces or areas without proper air circulation.
- Before beginning any exercise, consult with your doctor to ensure do not have any medical or physical conditions that could put your health and safety at risk. This consultation is essential if you are taking medication that affects your heart rate, blood pressure, or cholesterol level.
- Beware of your body's signals, as incorrect or excessive exercise can damage your health. Stop your workout and consult with your doctor immediately if you experience any of the following:
 - Dizziness
 - Nausea
 - Chest pain
 - Back pain
 - Any other health-related symptoms
- Do not use any exercise equipment if it is not assembled properly. Be sure to inspect your machine periodically to ensure all nuts and bolts are securely tightened and that your machine is in good condition.
- This machine is designed for adult use only and is not suitable for therapeutic use. Keep children and pets away from the equipment.
- Do not use this item in a way inconsistent with the manufacturer's instructions as this could void the product warranty. If any components are defective while assembling or checking the equipment, or you hear any unusual noises from the equipment, immediately stop use and do not resume until the problem has been resolved.
- Wear appropriate clothing while working out; do not wear a robe or any other clothing that could become caught in the machine. Also, be sure to wear running or aerobic shoes.
- Keep hands away from all moving parts. Always be sure to lift or move the equipment carefully.

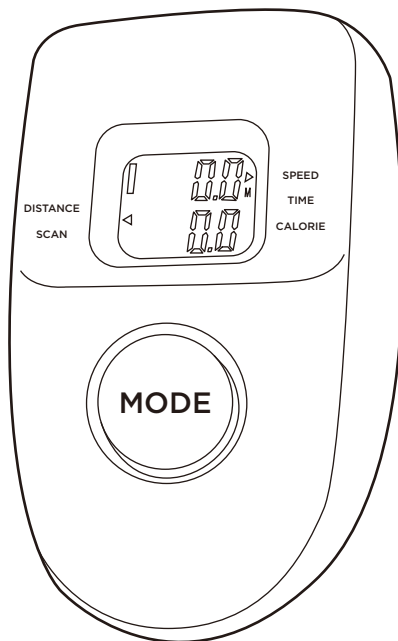

Functional Buttons

- Mode: Press this button to select a function to display. Press and hold to reset all functions.

Function and Operations

- Scan: Press the "MODE" button until "SCAN" is selected. The monitor will then rotate through all 3 functions - Time, Distance, Calories - and display each for 4 seconds.
- Time: Press the "MODE" button until "TIME" is selected. This displays the total time of your workout from start to finish.
- Speed: Displays your current speed.
- Distance: Press the "MODE" button until "DISTANCE" is selected. This displays the total distance of your workout from start to finish.
- Calories: Press the "MODE" button until "CALORIE" is selected. This displays the total calories burned during your workout from start to finish
- Auto ON/OFF & Auto START/STOP: Power will turn off automatically after 8 minutes of non-use. The display monitor will remain on as long as the wheel is in motion or when any button is pressed.

NOTICE



- Please read these assembly instructions carefully before installing.
- Firmly secure all screws before use.
- Product is intended for indoor use only.
- If any parts are missing, broken, damaged, or worn, stop using this item until repairs are made and/or factory replacement parts are installed.
- Do not use this item in a way inconsistent with the manufacturer's instructions as this could void the product warranty.

TENSION ADJUSTMENT

- Before beginning your first workout, adjust the tension to a desirable level.
- When starting your exercise, simply use the tension adjustment knob (found at the top center) to manipulate the tension you feel. Turning the knob clockwise will provide stronger tension, while turning it counter-clockwise will ease the tension.
- For more adjustment, you may loosen the friction belt or tighten it by re-strapping it.

PRODUCT WARRANTY INFORMATION

All items can be returned for any reason within 60 days of the receipt and will receive a full refund as long as the item is returned in its original product packaging and all accessories from its original shipment are included. All returned items will receive a full refund back to the original payment method. All returned items will not be charged a re-stocking fee.

All returned items require an RA (Return Authorization) number, which can only be provided by a Best Choice Products Customer Service Representative when the return request is submitted. Items received without an RA may not be accepted or may increase your return processing time. Once an item has been received by Best Choice Products, refunds or replacements will be processed within 5 business days.

All returns must be shipped back to the Best Choice Products Return Center at the customer's expense. If the reason for return is a result of an error by Best Choice Products then Best Choice Products will provide a pre-paid shipping label via email. Boxes for return shipping will not be provided by Best Choice Products, and is the customer's responsibility to either use the original shipping boxes or purchase new boxes.

Pictures may be required for some returns to ensure an item is not damaged prior to its return. Items returned are not considered undamaged until they are received by Best Choice Products and verified as such. All damages to items are the customer's responsibility until the item has been received by and acknowledge by Best Choice Products as undamaged.

CONTACT US; WE'RE HERE 7 DAYS A WEEK TO HELP YOU!



bestchoiceproducts.com



customerservice@bestchoiceproducts.com



844.948.8400



[LEARN MORE!](#)

WARNING

Manufacturer and seller expressly disclaim any and all liability for personal injury, property damage or loss, whether direct, indirect, or incidental, resulting from the incorrect attachment, improper use, inadequate maintenance, or neglect of this product.